

Speed Control

WV-M 0,25

WV-M 0,35

WV-M 0,5x19

WV-M 1,0

WV-M 1,0x40



ONLINE
Calculation and
2D / 3D CAD Download

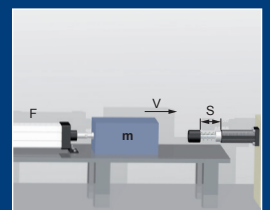

Features

Enlarged Piston:

- Max. +400% Energy
- Max. -50% Costs / Nm



Integrated End Stop:

- Max. security



Versions:

- Housing: ProSurf
(Surface protection against corrosion)
- Piston rod: Hardened stainless steel



Extended Life Time:

- Special Seals + Oils

Temperature:

- Standard: -20°C - +80°C
- Low-temperature: -50°C - +60°C
- High-temperature: 0°C - +120°C

Speed rates:

- 0,015 - 40 m/min

Stop cap:

A:

- Standard from POM
- Increased protection of the impact surface

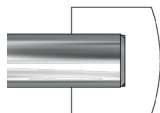

AP:

- 40% noise reduction
- Increased protection of the impact surface

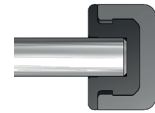

AP2:

- Longer life time compared to stop cap AP and plastic cap A

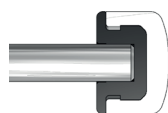

AS:

- from hardened steel
- for difficult operating conditions



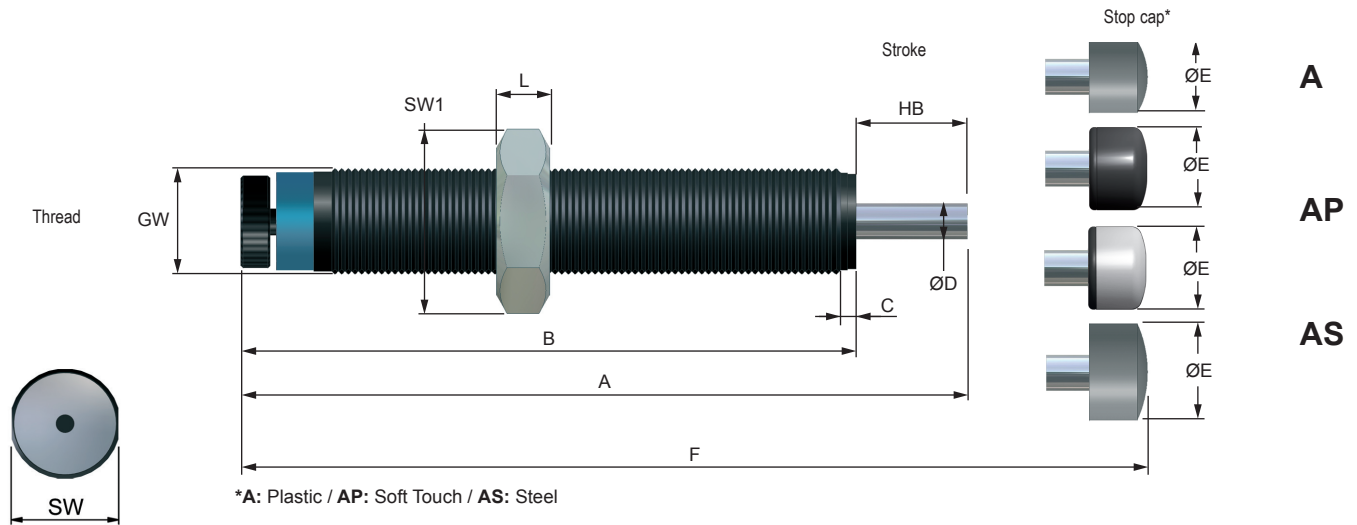

DIMENSIONS

	GW	A	B	C	Ø D	ØE (A)	ØE (AP)	ØE (AS)	F (A)	F (AP)	F (AS)	K	L	SW	SW 1
		mm	mm	mm	mm	mm	mm	mm	mm	mm	mm	mm	mm	mm	mm
WV-M 0,25	M 14x1	96	82	2,5	4	10	10	10	105	105	105	4	5	13	17
WV-M 0,35	M 16x1	96	82	2,5	4	10	10	10	105	105	105	4	6	14	19
WV-M 0,5x19	M 20x1	113	94	2,5	6	12	12	17	123	125	123	6	6	18	24
WV-M 1,0	M 24x1,5	141	114	3,5	8	16	21	20	154	156	154	6	8	23	30
WV-M 1,0x40	M 24x1,5	178	136	3,5	8	16	21	20	191	193	191	6	8	23	30

PERFORMANCE

	Stroke	Speed force		Speed rates		Return spring force		Weight
		min. N	max. N	m / min -1	m / min -2	min. N	max. N	
WV-M 0,25	14	20	500	12 - 40	0,015 - 15	13	23	50
WV-M 0,35	14	20	700	12 - 40	0,015 - 15	13	23	70
WV-M 0,5x19	19	25	1800	12 - 40	0,015 - 15	12	23	140
WV-M 1,0	25	70	3600	12 - 40	0,015 - 15	15	31	290
WV-M 1,0x40	40	80	3600	12 - 40	0,015 - 15	11	20	390

Accessories

Stop limit nut

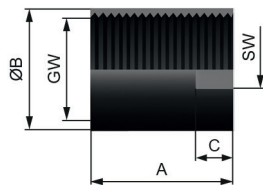

GW*	A mm	ØB mm	C mm	SW mm	Code
M14x1	20	18	6	15	21058
M16x1	25	21	8	19	22158
M20x1	35	25	8	22	21158
M24x1,5	38	31	10	30	21238

Clamping flange

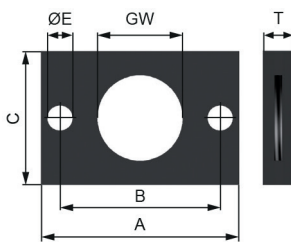

GW*	A mm	B mm	C mm	E mm	T mm	Code
M14x1	34	26	20	5,5	6	SK21053
M16x1	34	26	20	5,5	6	SK22153
M20x1	46	36	30	6,6	8	SK21153
M24x1,5	52	42	35	6,6	8	SK21233

Rectangular

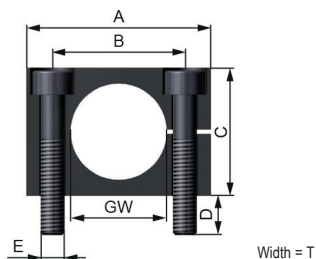

GW*	A mm	B mm	C mm	D mm	E mm	T mm	Code
M14x1	32	20	20	5	M5	12	S21053
M16x1	40	28	25	6	M6	20	S22153
M20x1	40	28	25	6	M6	20	S21153
M24x1,5	46	33	32	6	M6	25	S21233

Width = T

Accessories

Lock nut

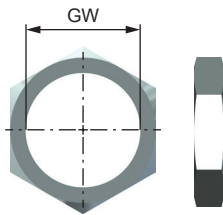

GW*	Code
M14x1	21052
M16x1	22152
M20x1	21152
M24x1,5	21232

Proximity Switch

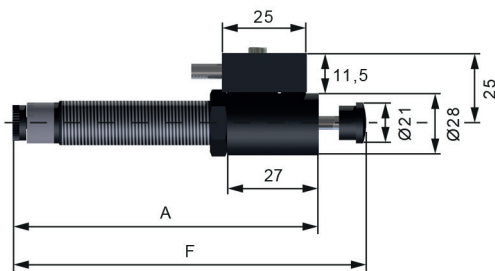

Included

Proximity Switch,
Switch cap,
Stop limit nut

	A (mm)	ØE (mm)	F (mm)	G (mm)	Code
WV-M 0,25	92,0	19	100	20,5	S31064
WV-M 0,35	90,0	21	100	21,5	S31254
WV-M 0,5x19	101,5		123		S32164
WV-M 1,0	122,5		154		S33064
WV-M 1,0x40	144,5		191		S33064

	A (mm)	F (mm)	Code
WV-M 0,5x40	138,5	181	S32164

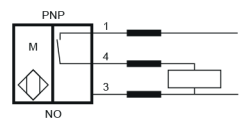

Accessories

Clevis mounting

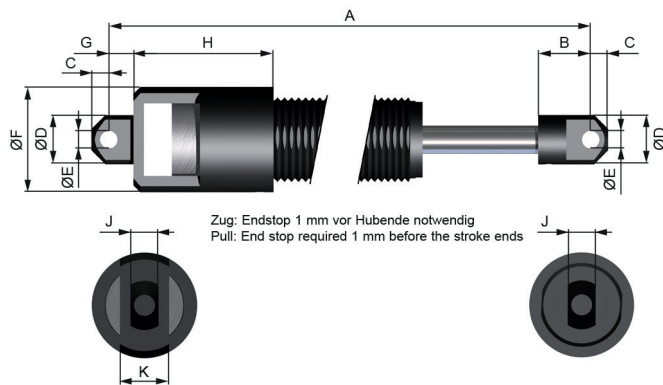

	GW*	A mm	B mm	C mm	øD mm	øE mm	øF mm	G mm	H mm	J mm	K mm
WV-M 0,5x13SB	M20x1	119	13	5	12	5	26	5	35	6	12
WV-M 0,5x19SB	M20x1	138	13	5	12	5	26	5	35	6	12
WV-M 1,0SB		158	15	5	14	5	30	7	40	8	14

Schock absorber with protection below

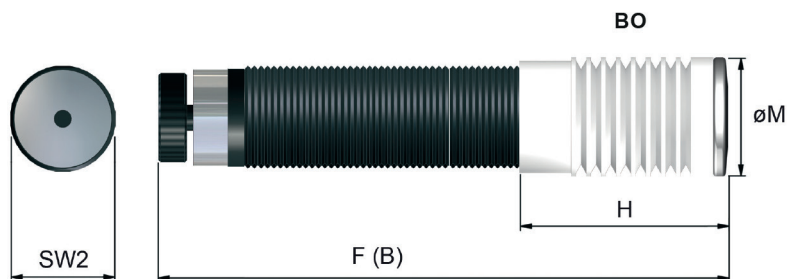

Material: PTFE / Stop cap: stainless steel
Ordering information: WV-M 0,5 x 19 - BO

AK 1

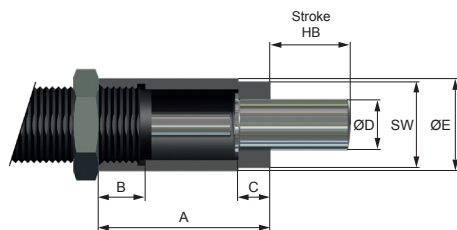

	GW*	A mm	B mm	C mm	øD mm	øE mm	SW mm	Code
WV-M 0,25	M 14 x 1	32	10	6	9	18	15	S21019
WV-M 0,35	M 16 x 1	33	10	5	12	20	17	S22119
WV-M 0,5x19SB	M 20 x 1	42	16	8	12	24	22	S21119
WV-M 1,0	M24 x 1,5	53,5	14,5	10	16	29	27	S21219

AK 2

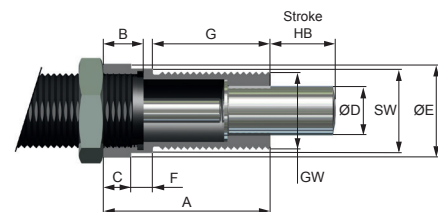

	GW*	A mm	B mm	C mm	øD mm	øE mm	F mm	G mm	SW mm	Code
WV-M 0,25	M14 x 1	32	8	8	8	18	4	20	16	S21019-AK2
WV-M 0,35	M 16 x 1	32	8	8	8	20	4	18	19	S22119-AK2
WV-M 0,5x19SB	M 20 x 1	38	9	6	12	24	7	25	22	S21119-AK2
WV-M 1,0	M24 x 1,5	54	13	9	16	30	7	38	27	S21219-AK2

Installation

Installation with stop limit nut

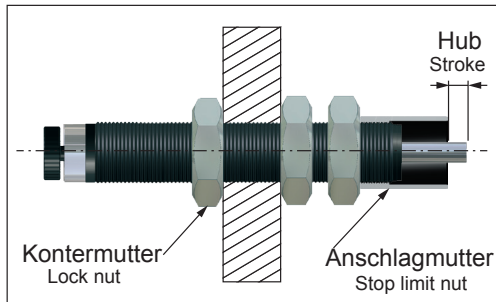

Installation with flange

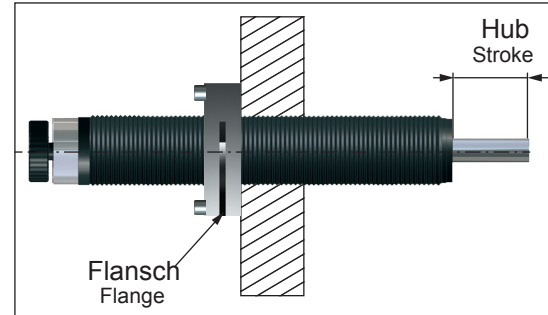

Installation with lock nut

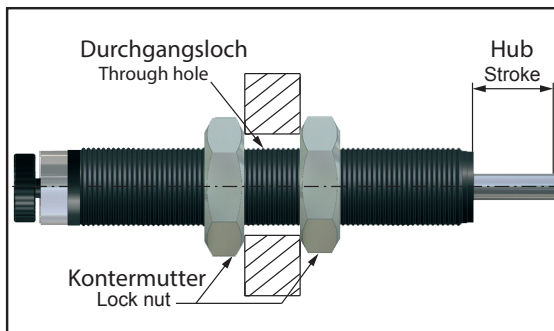

Clevis mounting

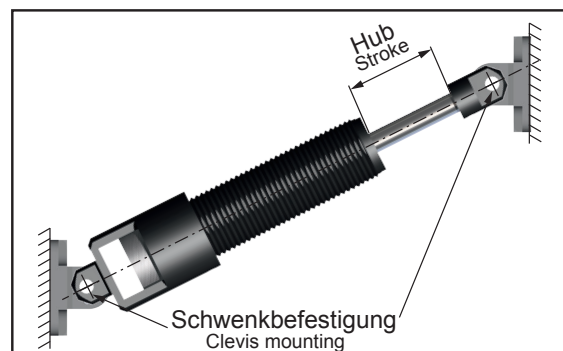

Adjustment

The damping factor is adjusted with the adjusting screw at the back-sided end of the Speed control. The damping depends from the impact speed and the effective mass. Set possibilities on the scale 0-8

0 = low damping
8 = high damping



A hexagonal key is supplied for this purpose.



Safety Instructions

Before Installation, commissioning, servicing and repair the data sheet is to be noticed. This work may only be performed by trained, introduced staff.

Electric connections according to the suitable national regulation. For Germany: VDE regulation VD E0100

Before all repair and servicing works the energy supplies (main switch, etc.) have to be switched off! Moreover, measures are necessary to prevent an unintentional reconnect. For example, a warning sign "service works" or "maintenance work", applied to the switch.

Designated use

Check before installation and make sure the type name on the shock absorber or on the packaging is corresponding with delivery note. Industrial shock absorbers are maintenance-free and ready for installation.

- Temperature influence: at higher temperatures the shock absorber characteristic will change.
- Movable loads have to be protected during the installation and maintenance against unintentional processes.
- In operation outside the allowed temperature range, the shock absorber can lose his function. Due to heat radiation don't paint the shock absorber.
- Fluids, gases and a dirty environment can affect or destroy the sealing system of the shock absorber. The result could be a failure malfunction. Piston rod and sealing system has to be protected against fluids, gases and a dirty environment.
- Damages at the piston rod can destroy the sealing system. Don't grease or oil the piston rod.
- Avoid traction forces on the piston rod to present internal damages.
- The shock absorber can be pulled out of the construction during the impact. The construction needs to be able to resist the max counterforce. Sufficient security must be calculated.
The maximum counterforces performed in the calculation program can vary from the really appearing counter forces, because these are based on theoretical values.

Basic information

Speed control may under no circumstances be:

-painted



-welded



-held with clamps



-used on pull



In hazardous environments (dirt, humidity, oil) shock absorbers must be protected against damage and failure with the necessary accessory. If several Speed control are used on the same application, the deceleration has to be distributed equally. The "Torque" (PERFORMANCE) indicates the maximum force by using the flats. The Weforma catalogue shows technical data with both minimum and maximum values. If a product is to be used in continuous operation and within a range of 20% from the minimum and maximum values shown, then written confirmation of suitability of use from Weforma is necessary.

Integrated end-stop

For the WV-M series the shock absorbers are provided with an integrated end-stop. If the integrated end-stop is used the remaining energy before end of stroke must not be higher than 10% of the total energy.

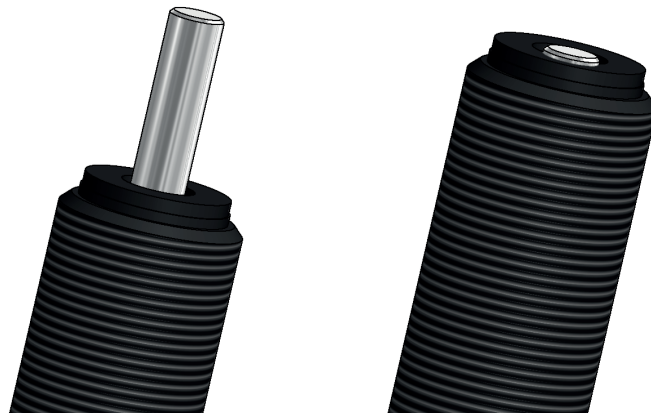

Installation situation

The installation situation is any, however always in such a way that the complete speed control stroke can be used. The speed control must be mounted like that the forces in centerline about the piston rod are initiated. The maximum angle out of centre amounts to 2°. With a bigger angle out of centre an AK1 / AK2 (see equipment) must be used.

Liability

Due to the number of possible uses of our products and the conditions of use that lie outside of our scope of influence, we accept no liability as to whether the purchase object is suitable for the Client's intended purpose. The verification to this effect, in particular the verification as to whether the purchase object is suitable for the planned use, is the responsibility of the Client alone, unless expressly agreed otherwise in writing.

For the reasons we accept no liability for the suitability of the purchase object for the purpose intended by the Client, except in cases of intent or gross negligence.

With damages, the not designated use and from high-handed, in these instructions do not originate to intended interventions, any guarantee and liability claim goes out towards the manufacturer.

Guarantee

By non-use of the original spare parts the guarantee claim goes out.

Environment protection

By the exchange from damaged parts is to be respected to a proper disposal.